

## HOMOLOGATION OF CHASSIS

<i>Manufacturer</i>	BIREL ART
<i>Make</i>	BIREL ART
<i>Model</i>	C28
<i>Category</i>	<b>Minikart / Bambini</b>
<i>Valid as from</i>	<b>01 January 2017</b>
<i>Valid until</i>	<b>31 December 2022</b>
<i>Number of pages</i>	<b>5</b>

*Any modification is forbidden, if it is not explicitly allowed by the Technical or Homologation Regulations and/or appended as an approved extension.*

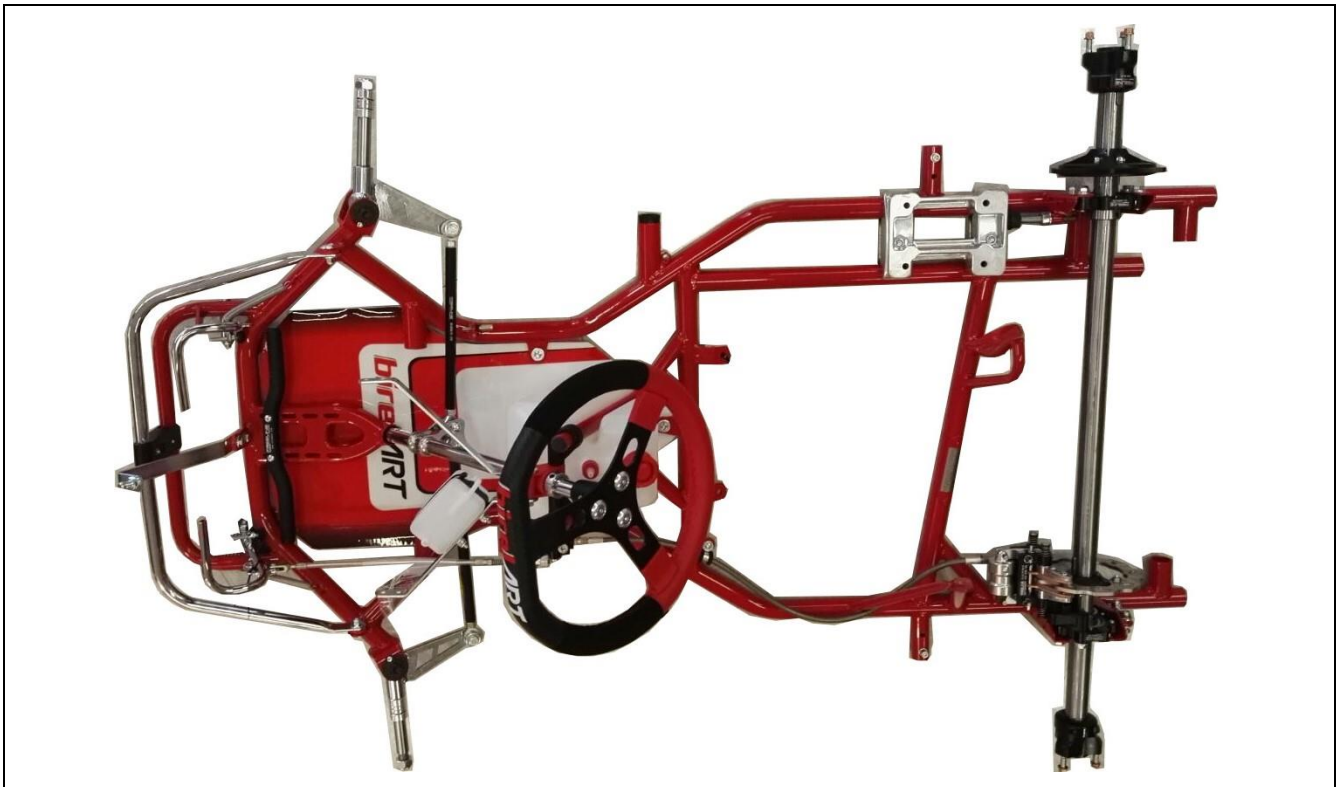

*Photograph of the chassis less seat, brakes, tyres, bumpers and bodywork*

### SIGNATURE AND STAMP OF THE DMSB/MSA

	<p>Date: <b>15 December 2016</b></p> <p>Signed by: <b>Joe Hickerton &amp; Christoph Ihm</b></p> <p>Position: <b>DMSB/MSA Homologation Department</b></p>
--	--

**TECHNICAL DRAWINGS OF FRAME WITH MAIN DIMENSIONS**

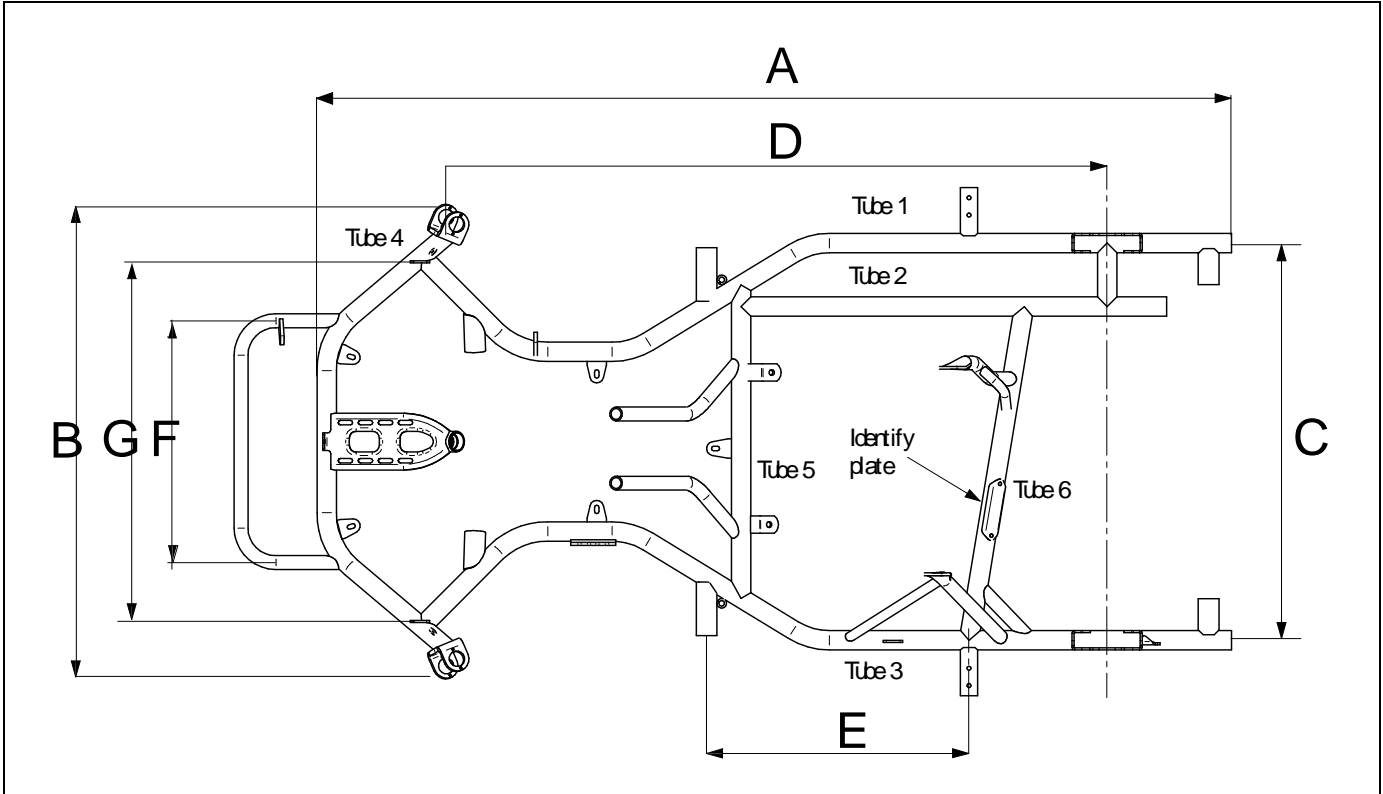

*Top view in scale 1:10 with labels of table 1 (frame with all brackets and supports)*

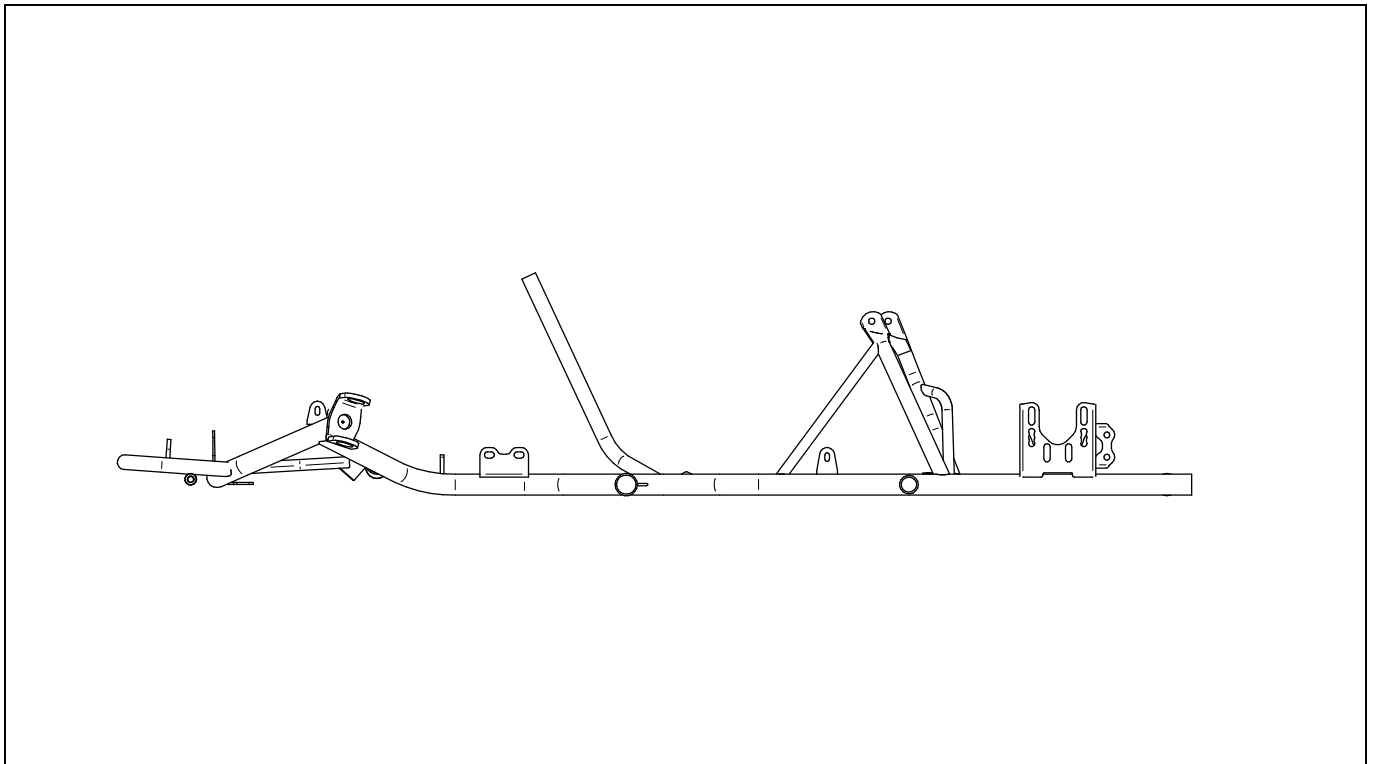

*Side view in scale 1:10 with labels of table 1 (frame with all brackets and supports)*

**TABLE 1: DIMENSIONS OF FRAME AND REAR AXLE**

Label		<i>Measurement</i>	<i>Tolerance/Remarks</i>
<b>A´:</b>	Total length (w/o. front bumper)	<b>1320</b>	+/- 10 mm
<b>B´:</b>	Width at front axle*	<b>660</b>	+/- 5 mm
<b>C´:</b>	Width at rear axle	<b>580</b>	+/- 5 mm (centre to centre) mandatory: 600 +/- 25 mm
<b>D´:</b>	Wheelbase (mandatory)	<b>950 mm</b>	+/- 5 mm
<b>E´:</b>	Distance of supports for side bodywork	<b>380 mm</b>	+/- 5 mm mandatory acc. drawing 18a of CIK-TR
<b>F´:</b>	Distance between front bumper lower mountings	<b>350 mm</b>	+/- 5 mm mandatory acc. drawing 18a of CIK-TR
<b>G´:</b>	Distance between front bumper upper mountings	<b>500 mm</b>	+/- 5 mm mandatory acc. drawing 18a of CIK-TR
* measured from the outermost point of the front axle			
<b>Tube data</b>			
	Number of bends	<b>8</b>	max. 8
	Number of tubes	<b>6</b>	Mandatory
	Diameter	<b>28 mm</b>	+/- 0.5 mm
	Wall thickness	<b>2.0 mm</b>	+/- 0.2 mm
	Material	<b>Magnetic steel</b>	Mandatory
	Number of bearings	<b>2</b>	Mandatory
<b>Rear axle data</b>			
	Material	<b>Magnetic steel</b>	Mandatory
	Diameter	<b>max. 30 mm</b>	Mandatory
	Wall thickness	<b>min. 4.9 mm</b>	Mandatory
	Length	<b>960 mm</b>	+/- 10 mm
	Weight	<b>2,900 g</b>	+/- 100 g

All pre-defined data including possible tolerances must be respected.

**STEERING COLUMN ADAPTION (mandatory)**

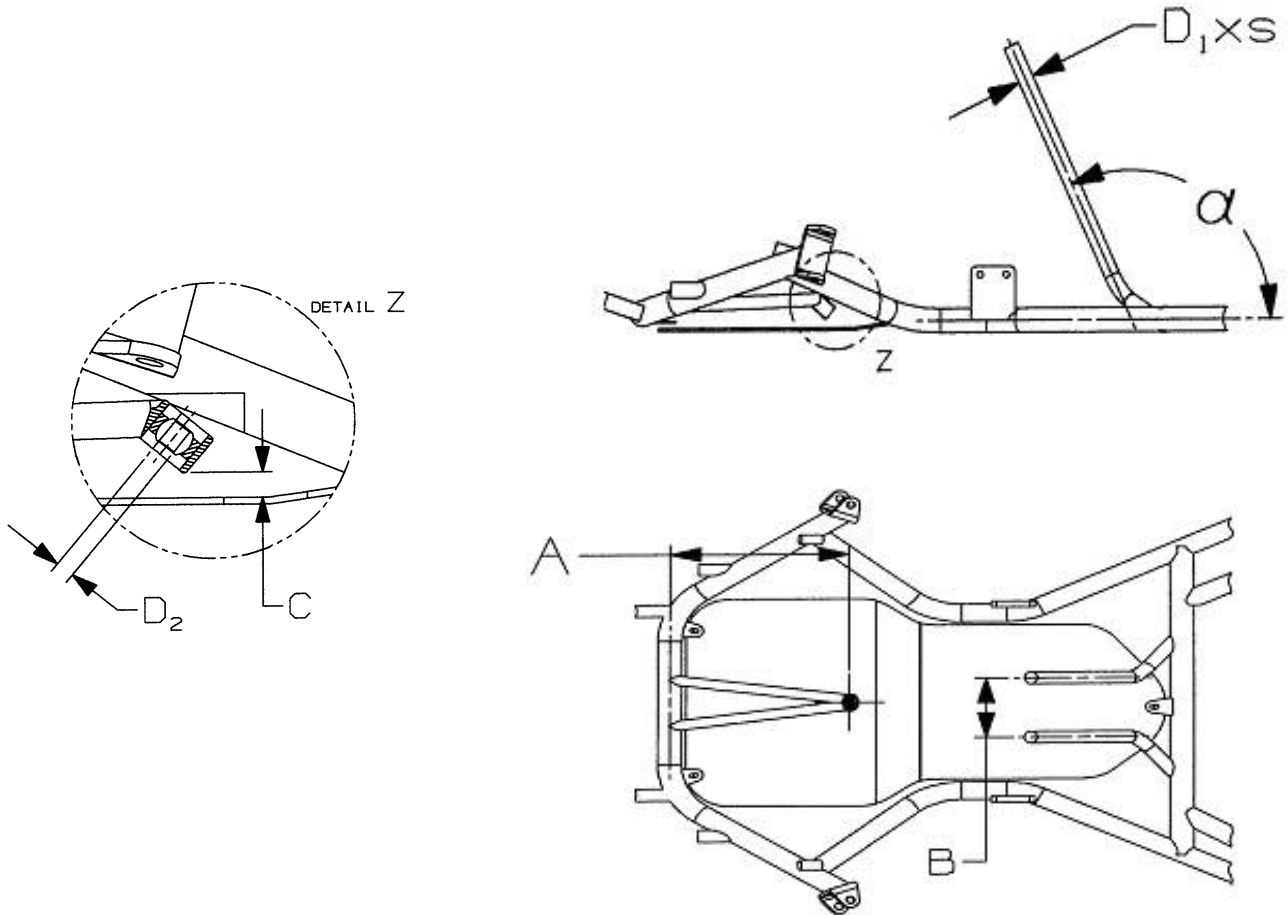

**TABLE 2:**

	Dimension (real)	Mandatory dimensions	Tolerances/remarks
$\alpha$	115	<b>115°</b>	$\pm 10^\circ$
<b>A</b>	185	<b>180 – 240 mm</b>	Design optional
<b>B</b>	100	<b>100 mm</b>	$\pm 2$ mm Distance of tank struts (parallel)
<b>C</b>	12	<b>15 mm</b>	$\pm 5$ mm Distance to the upper edge of the floor
<b>D<sub>1</sub> x s</b>	20 x 2	<b>20 x 2 mm</b>	$\pm 0.5$ mm Diameter and thickness of tank struts
<b>D<sub>2</sub></b>	8	<b>8 or 10 mm</b>	$\pm 0.1$ mm Diameter of column bearing pin (Uniball)

**COMPLIMENTARY INFORMATION**

## HOMOLOGATION NUMBER MARKING



*Photograph of Homologation Number marking*



*Photograph / drawing of position of Homologation Number marking*