

HOMOLOGATION OF CHASSIS

<i>Manufacturer</i>	GILLARD
<i>Make</i>	GILLARD
<i>Model</i>	110
<i>Category</i>	Formula Cadet
<i>Valid from</i>	1 st January 2011
<i>Valid until</i>	31 st December 2019
<i>Number of pages</i>	4

This Homologation Form reproduces descriptions, illustrations and dimensions of the chassis at the moment of the MSA homologation. The Manufacturer may modify them, but only within the limits set by the MSA regulations in force and with the written agreement of the MSA.

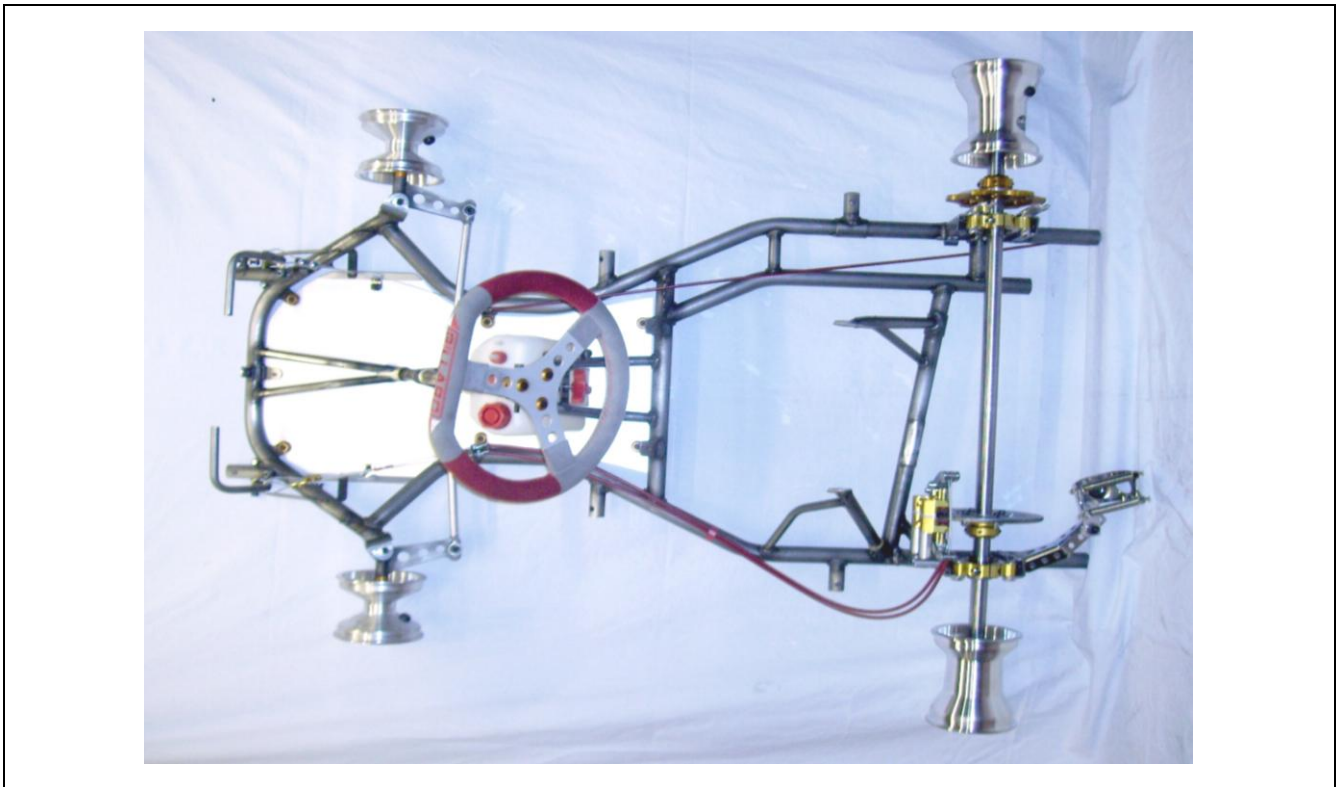

Photograph of complete chassis less seat and bumpers

SIGNATURE AND STAMP OF THE MSA

	Date: 1st January 2011 Signed by: John Ryan Position: MSA Technical Executive
-------------------------------------------------------------------------------------	-----------------------------------------------------------------------------------------------------------------------------

TECHNICAL DRAWINGS OF FRAME WITH MAIN DIMENSIONS

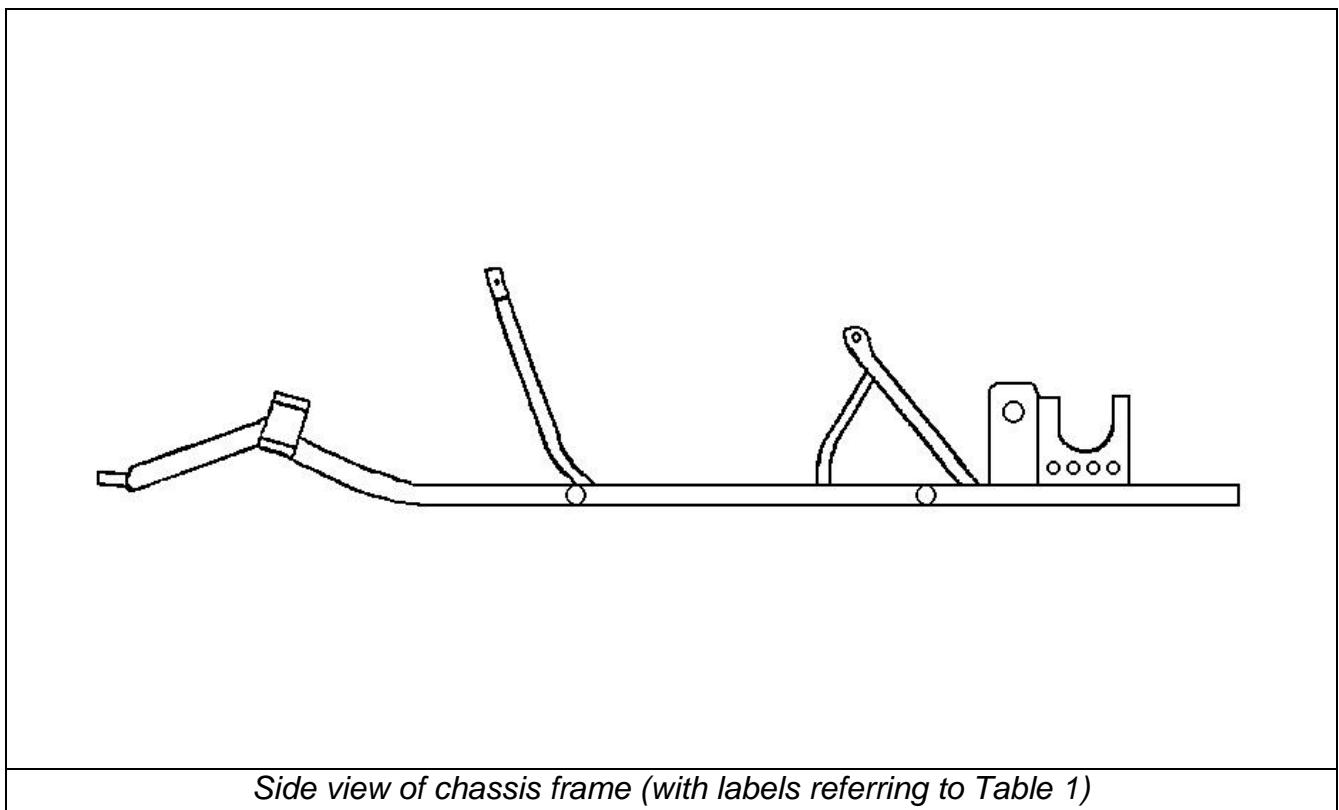
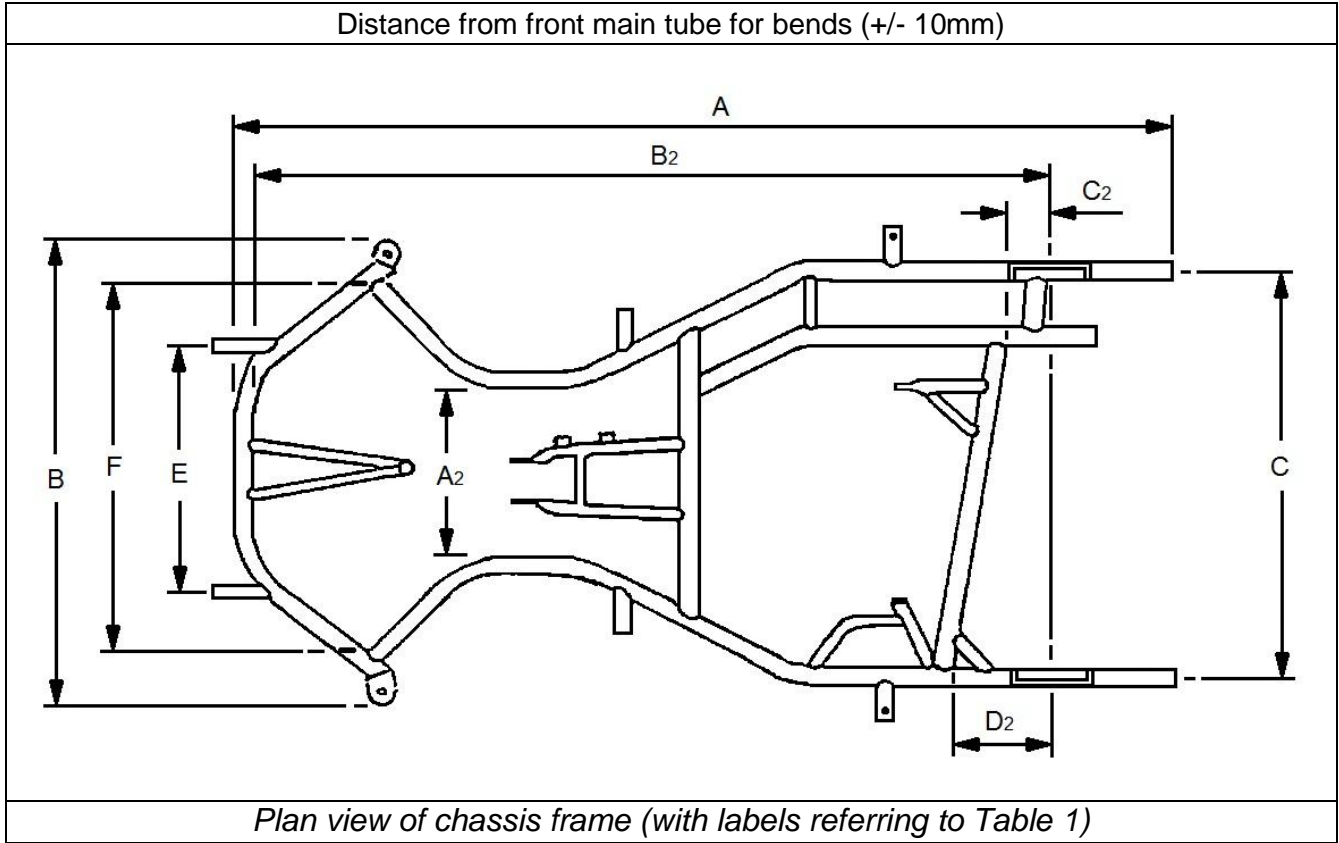

TABLE 1 – DIMENSIONS OF FRAME

		<i>Measurement</i>	<i>Tolerance / Remarks</i>
A:	Total length (w/out front bumper)	1343 mm	+/- 10 mm
B:	Outer front width	640 mm	+/- 10 mm
C:	Rear width *	580 mm	+/- 5 mm (600 ± 25mm mandatory)
D:	Distance between side bumper mounting points *	380 mm	+/- 5 mm
E:	Distance between front bumper lower mountings *	350 mm	+/- 5 mm
F:	Distance between front bumper upper mountings	499 mm	+/- 5 mm (outer)
G:	Number of bends	9	-
H:	Wheelbase	900 mm	+/- 5 mm
I:	Number of tubes	6	($\varnothing > 21\text{mm}$; length > 150mm)
J:	Diameter	28 mm	+/- 0.5 mm
K:	Wall thickness	2.0 mm	+/- 0.1 mm
L:	Material	Magnetic Steel	mandatory
M:	Number of bearings	2	mandatory

* Distance between centres of tubes

TABLE 2 – ADDITIONAL INFORMATION

		<i>Measurement</i>	<i>Tolerance</i>
A:	Inner waist width	234 mm	+/- 10 mm
B:	Inside edge of front tube to centreline of rear axle	1122 mm	+/- 10 mm
C:	Rear edge of rear cross rail mounting point to centreline of axle – engine side	44 mm	+/- 10 mm
D:	Rear edge of rear cross rail mounting point to centreline of axle – opposite side	120 mm	+/- 10 mm

COMPLIMENTARY INFORMATION

'Mirror Image' Honda variant permitted

Imperial equivalent tube used.

DETAILS OF IDENTITY PLATE



Photograph of I.D. plate

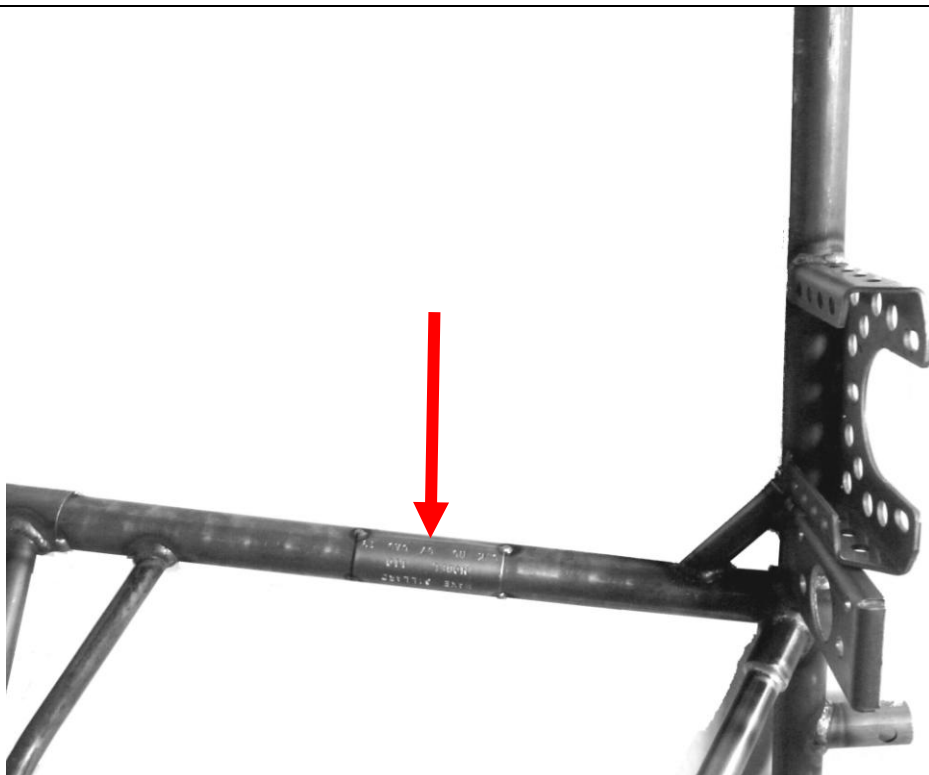

Photograph / drawing of position of I.D. plate

EXTENSION TO CHASSIS HOMOLOGATION

<i>Manufacturer</i>	GILLARD
<i>Make</i>	GILLARD
<i>Model</i>	110
<i>Category</i>	Formula Cadet
<i>Valid from</i>	1 st January 2012
<i>Number of pages</i>	1

For left hand engine mount 'Honda' variant, left hand side seat stay is adjusted as per the image below



SIGNATURE AND STAMP OF THE MSA	
	Date: 1st January 2012 Signed by: John Ryan Position: MSA Technical Executive