REGULATION CHANGES

RATIFIED BY BOARD – 25 NOVEMBER 2020

SUPPORTED BY RULES COMMITTEE – VIA E-MAIL

Section F - Emergency & Medical Services

Rescue, Stage Safety and Rally Recovery Units and Equipment

Powered Tools (for Rescue Units)

.....

~~1 pedal cutter 3cm minimum jaw opening~~

A cutter with a 3cm minimum jaw opening suitable for cutting pedals

Date of Implementation: Immediate

Reason: It is recommended that the equipment carried is suitable for use on modern-build vehicles.

Tools (for Rescue Units and Recovery Units)

.....

~~1 small axe delete~~

Date of Implementation: Immediate

Reason: Agreed to remove from all units as this item was deemed to be outdated and ineffective.

Section K - Competitors : Safety

Seats, Seat Belts and Headrests

K2.1.12. Elastic devices attached to the shoulder straps are forbidden.

Date of Implementation: Immediate

Reason: Elastic devices attached to harness shoulder straps to aid egress are a safety concern as they may pull the shoulder straps off the FHR. The regulation copies an FIA regulation which prohibits their use.

K2.2.1.1. For new build vehicles from 1st January 2021, where transverse seat mounting rails are used, they must be compliant with drawing No. K64(a) or homologated by the FIA or an FIA recognised ASN. ~~In the case of drawing No. K64(a) ±~~ The end plates may alternatively be welded to the counterplate. **Multiple mounting holes, to a maximum of 4 at each mounting point, are permitted as shown in K64(b)-(c)**

K2.2.1.2. Drawing K64(a)-(c) Material specification

Tube

Cold Drawn Seamless Unalloyed Carbon Steel

Minimum Yield strength 350N/mm²

Minimum dimensions 35mm diameter x 2.5mm wall thickness

Box Section (Structural)

Unalloyed Carbon Steel

Minimum Yield Strength 350N/mm²

Minimum dimensions 35mm square x 2.5mm wall thickness

K2.2.1.3. Any mounting holes drilled in the seat rails must have bushes installed, these must be fully welded. The bushes must be profiled to prevent them being pulled through, alternatively they may be of 'top hat' type inserted from below. Minimum bush diameter 13mm for M8 bolts, 15mm for M10 bolts. Multiple bush positions are permitted.

K2.2.1.4. The minimum overall length of the "U" shape extruded section is 50mm with a 2.5mm wall thickness.

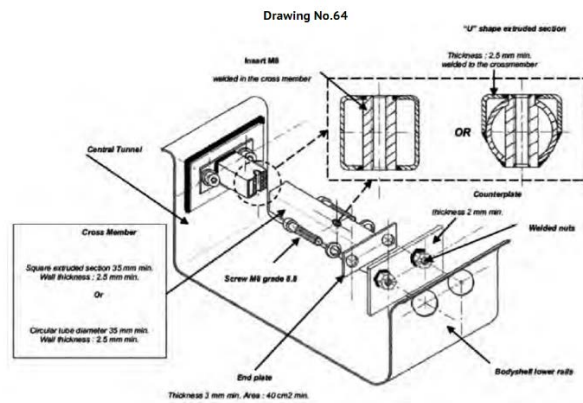

K64(a)

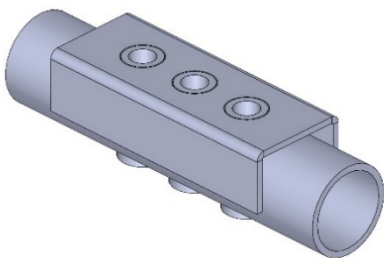

K64(b)

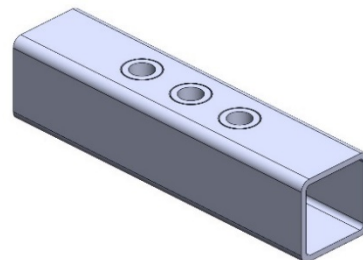

K64(c)

Date of Implementation: Immediate

Reason: to provide more detail on the seat mounting rail installation requirements, specifying a minimum material specification and more detailed installation instructions. It also clarifies that the rail may have multiple mounting holes to provide adjustment in seat location.

Section S - Sprints, Hill Climbs and Drag Racing

S9.2.6. Deleted. Competition numbers must be covered or removed at all times whilst driving on the public highway.

Implementation: 1st January 2021

Reason: Reinstatement of previously deleted wording whilst adding “or removed”.

S11. Regulations for Standard Cars

S11.1. Description

.....

S11.1.3. Organisers may provide an Intro-Class which will allow new drivers to experience competitive motor sport on an event by event basis.

- a) The RS Clubman licence is acceptable
- b) The Class will run separate to any other session
- c) The vehicle must run on List 1A tyres

Implementation: 1st January 2021

Reason: Enabling the standard car class to be used as taster events whilst prohibiting inclusion in Championships and licensing on a pay as you play basis.